

Sentinel Eliminator Vortex[®]300

Compact filter for powerful magnetic filtration of system debris

Circulating debris in central heating systems can cause wear and premature failure of pumps, valves and heat exchangers. Sentinel Eliminator Vortex300, fitted to the return pipe on the boiler, will protect the system against all types of debris, and is ideal for installation in situations where space is restricted.

- **Compact design combined with in-line installation and 360° rotating T-piece**

For ease and speed of install on all orientations of pipework

- **Manufactured to automotive standards with robust body, dual seals and brass valves**

10 year guarantee for complete reassurance of long lasting quality

- **Flexible cleaning methods**

Providing fast and effective flushing on service or simple proof of collection

- **Unique Vortex Core with powerful neodymium magnet assembly**

Retains more magnetite than other leading small filters. Ensures the filter cannot block and can aid capture of other types of debris

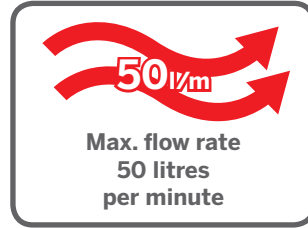
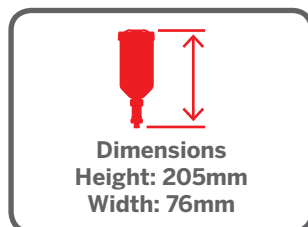

The Sentinel System

Lifetime protection for heating and hot water systems using the best practice process of...



CLEAN
WITH
APPROPRIATE
CLEANER



PROTECT
WITH X100
INHIBITOR



MAINTAIN
WITH
TEST KIT

Description

Sentinel Eliminator Vortex® system filter removes all types of debris commonly associated with wet central heating systems, affording boiler protection and helping to maintain optimum system operation and efficiency.

Operation

Sentinel Eliminator Vortex utilises a unique Vortex Core to deliver maximum contact time between circulation debris and powerful neodymium-iron-boron magnets. The Vortex Core reduces water flow rate and turbulence within the unit to enhance debris retention. It also ensures the filter will never block. The collected debris can be simply flushed away by removing the magnet from its sleeve and opening the drain valve at the base of the unit.

Additional features

Filter chamber capacity: 300ml

Compact design: Reduced height for easy installation into restricted spaces

Cannot block: Full unit does not affect system flow

Tamper-proof: Drain/push valve safety feature

Dosing point: For Sentinel Rapid-Dose® products

Technical specifications

Operating temp: 100°C

Operating pressure: 3 bar

Mounting: Main unit upright only – flow aligned with directional arrow

Connectors: 22mm compression

Weight (boxed): 1.7kg

Vortex300

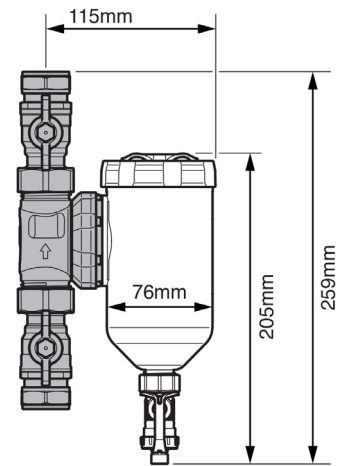

Pressure loss chart - Eliminator Vortex300

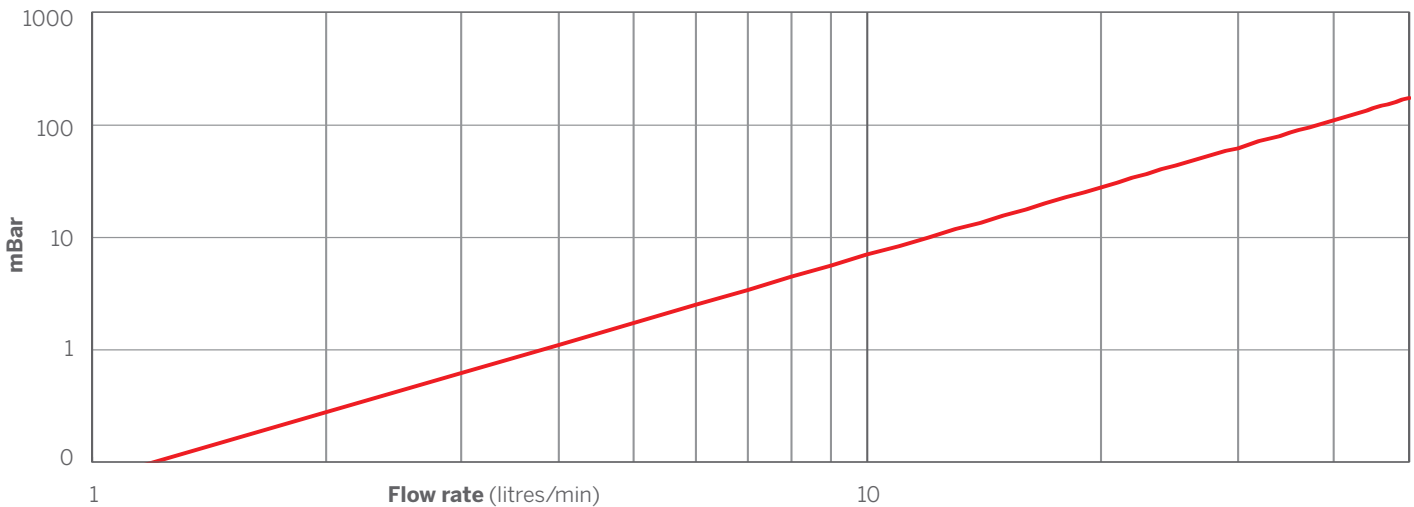

The use of Sentinel water treatment is endorsed by the industry's major international manufacturing companies*



Sentinel Performance Solutions Ltd

7650 Daresbury Park, Warrington, Cheshire, WA4 4BS, United Kingdom.

Tel: +44 (0)1928 704 330 www.sentinelprotects.com



@SentinelHQ



SentinelCPM